

ssia

•Canada

•United States

•China



23L PULSATING
Vacuum Steam Sterilizer



SANGIANG

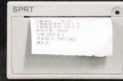

SQ-Z23

B class

Durable and Stable Performance

SQ-Z23 is the latest generation of Class B desktop sterilizer. Compared with competing products of the same type, the machine is equipped with a water quality detection probe, which can effectively avoid the formation of scale in the steam generator and pipeline, which affects the performance of the machine. 3.5' LCD display, more clearly and intuitively display the steam generator temperature, sterilization chamber temperature, pressure, door lock status, program running status, time and other parameters during the operation of the machine.



Efficiency

Utilisation of an intelligent systems and high performance components



Multi protection

overload protection and safety door locking system.



Mini thermal printer

Print the sterilization information on thermal paper whole cycle .



Low noise

High performance vacuum Pump the working noise lower 40 db



Reliability and safety

Full compliance with the European sterilizer standard and certified quality. Ensure a completed safety sterilization result.



For any load type

Class B steam sterilizer can be used steriize any load, such as the instruments of hollow, porous or solid.



Data export

Standard equipped with an internal memory able to store 10000+ cycles, and the cycle reports can be automatically saved via the USB driver.



Cooling unit

Two radiators with fans ensure that the exhaust steam temperature is reduced to below 80 degrees, reducing the risk of personal burns



Drain and exhaust ports



Air filter

Fuse

Safety valve



Sterilization room

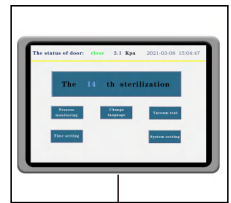

Display screen



Carrier



USB port



Water tank

Overall Dimension

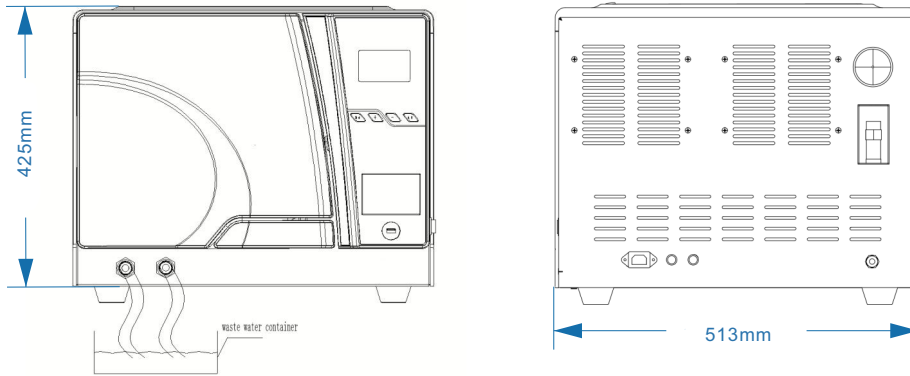

Rack & Trays Dimension

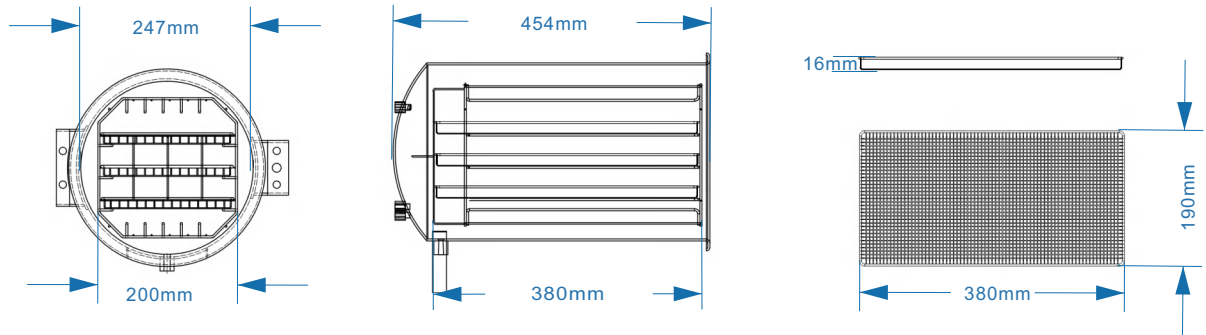

Technical parameters

| Model | Rated Power | Chamber Size | Machine Size |
|--------|-------------|--------------|---------------|
| SQ-Z23 | 1.7KVA | Φ246x450mm | 720X513x425mm |

| Material | Weight | Voltage | Water tank |
|----------|--------|----------|------------|
| SS304 | 50KG | AC 220 V | 2 Liter |



Sterilization Cycles

| Program | Temp. / Pressure | Steri. Time | Suitable For | SQ-Z23 |
|---------|------------------|-------------|---------------------|--|
| Metal | 134°C/220Kpa | 10min* | Metal instruments | Cycle Time* Drying Time* Load(Max) 10~25min 15min 4.5kg |
| Fabric | 134°C/220Kpa | 10min* | Fabric and dressing | Cycle Time* Drying Time* Load(Max) 10~25min 15min 4.5kg |
| Rubber | 121°C/220Kpa | 25min* | Rubber and plastic | Cycle Time* Drying Time* Load(Max) 25~40min 15min 4.5kg |
| BD test | 134°C/220Kpa | 3.5min* | Bovie Dick Test | Cycle Time* Drying Time* Load(Max) Load Textile(Max) 3.5~11.5min 8min 4.5kg 1kg |

*In addition to the above sterilization procedures, there are three tests: B&D test, drying test and Vacuum test.

*The cycle time is based on the load and with/without pre-heating.

*Drying time can be adjusted.

Steam Sterilization Supplies

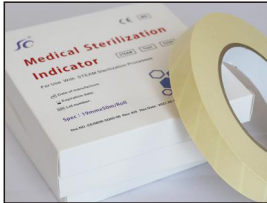

STEAM indicator tape

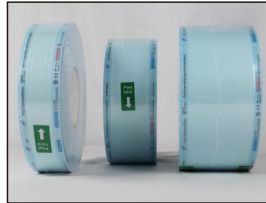

STEAM sterilization pouch



STEAM indicator strip



STEAM biological indicator



Biological Indicator Incubator

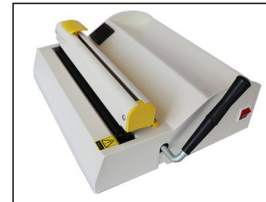

Heat sealing machine